



## SJIII 4740 ELECTRIC SCISSOR LIFT

### STANDARD FEATURES

- Drivable at full height with roll out deck fully extended
- Variable speed, front wheel hydraulic drive
- Flashing light
- DC Motor controller
- Dual holding brakes
- Proportional controls for drive & lift functions
- 0.90 m roll out extension deck
- 24V DC power source
- Low voltage battery protection
- Relay based control system
- Colour coded and numbered wiring system
- 25% gradeability
- Solid rubber, non-marking tyres
- Pothole protection system
- Wiring for AC outlet on platform
- Tilt alarm with drive & lift cut-out
- Overload sensing system
- Lowering warning system
- Operator horn
- Half height spring hinged gate
- Hinged railing system
- Lanyard attachment points
- Forklift pockets and tie down/lift lugs

### ACCESSORIES AND OPTIONS

- All motion audible alarm
- Dual flashing lights
- AGM batteries
- Drywall/board carrier
- Heavy duty pipe rack



Unit A12/A13  
Kenyon Court  
Walter Leigh Way  
Moss Industrial Estate  
Leigh, WN7 3PT

# SJIII 4740 ELECTRIC SCISSOR LIFT

Dimensions	SJIII 4740
<b>A</b> Work Height	13.80 m
<b>B</b> Raised Platform Height	11.80 m
<b>C</b> Lowered Platform Height	1.37 m
<b>D</b> Overall Width	1.19 m
<b>E</b> Overall Length (Platform Retracted)	2.40 m
<b>F</b> Stowed Height (Rails Up)	2.48 m
<b>G</b> Stowed Height (Rails Down)	2.21 m
<b>H</b> Platform Width (Inside Railing)	1.06 m
<b>I</b> Platform Inside Length (Retracted)	2.19 m
Specifications	SJIII 4740
Extension Deck (Roll Out)	0.90 m
Ground Clearance (Pothole Raised)	8.10 cm
Ground Clearance (Pothole Deployed)	1.90 cm
Wheelbase	1.85 m
Weight	2985 kg
Gradeability	25%
Turning Radius (Inside)	0.54 m
Turning Radius (Outside)	2.58 m
Lift Time (With Rated Load)	71 sec
Lowered Time (With Rated Load)	41 sec
Drive Speed (Stowed)	3.2 km/h
Drive Speed (Raised)	1.0 km/h
Maximum Drive Height	Full Height
Capacity (Overall)	350 kg
Maximum # of Persons (Indoor/Outdoor)	3/0
Tire Type	Solid, N/M
Tire Size	16 x 5 x 12

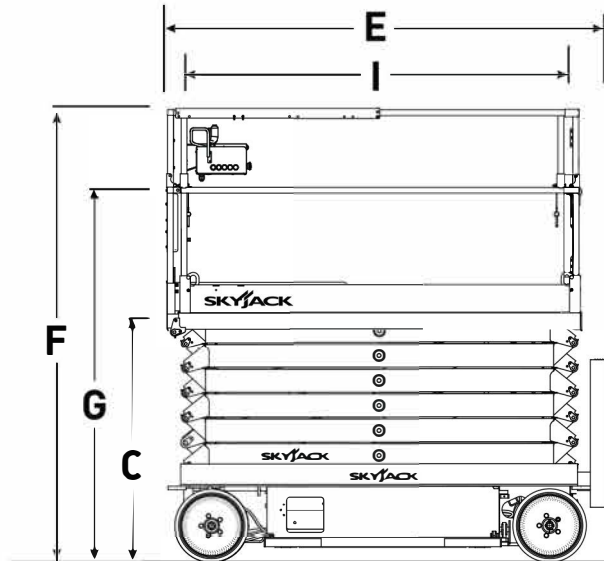
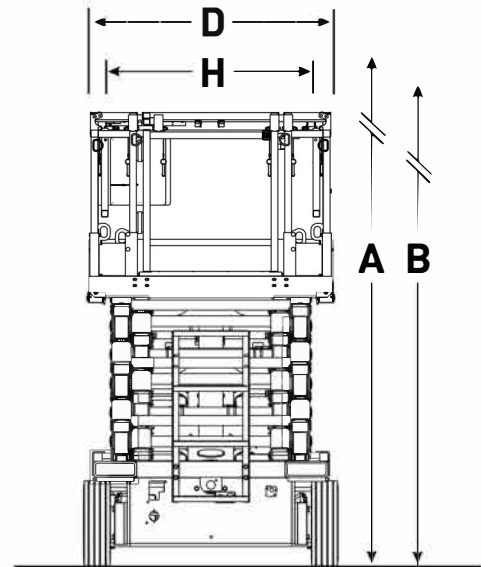

Unit A12/A13  
 Kenyon Court  
 Walter Leigh Way  
 Moss Industrial Estate  
 Leigh, WN7 3PT



0800 085 3709

info@aerialplatforms.co.uk