

# 1500AJP

## ARTICULATING BOOM LIFTS



### PRODUCTIVITY REDEFINED

- Providing largest working outreach in the industry while class-leading capacity allows for more materials to the work area
- Quickstik enabled boom operation means operators spend more time working and less time positioning
- Automatic axle deployment allows for set-up within 1 minute
- Minimal work interruption due to driveability at full height

### OPERATOR CONFIDENCE

- More stable operation due to wide axle foot print
- LCD display in platform keeps operator fully informed on location in work envelope
- Advanced hydraulics and cylinder dampening provides for smooth ride and deployment functions
- Equipped with JLG SkyGuard™ protecting the operator control panel

### TRANSPORTABILITY

- Fits on most standard trailers
- 50/50 weight distribution enables more stable on- and offloading

### Standard Features

- 0.91 x 2.44 m Platform
- Articulating Jib
- Dual Rated Capacities (270 kg / 450 kg)
- Drive-Out Extendable Axles
- 180° Hydraulic Platform Rotator
- AC Receptacle in Platform
- Tilt Light and Alarm
- Swing-Out Engine Tray
- 12V-DC Auxiliary Power
- Hourmeter
- Control ADE®  
Advanced Design Electronics System
- Hydrostatic drive transmission
- Proportional Controls
- Gull-Wing Steel Hoods
- Platform Console Machine Status Light Panel<sup>2</sup>
- Lifting/Tie Down Lugs
- Engine Distress Warning/Shutdown-Selectable via JLG Analyzer
- All Motion Alarm
- LCD Panel at Operator's Platform Control Console
- Quik Stik®
- Tool Tray
- JLG Skyguard active system
- Low fuel engine cut-out
- Cast Aluminum Control Box
- Horn
- Side entry with drop bar mid rail
- Interactive Display at Ground Controls

2. Provides indicator lights at platform control console for system distress, fuel level, low fuel, 5 degree tilt light and foot switch status.

### Standard Specifications

Power Source	
• Diesel Engine Deutz TCD 3.6 T4F	74.4 kW
• Fuel Tank Capacity	170 L
Hydraulic System	
• Hydraulic Tank Capacity	352 L
Tyres	
• Standard	445/50D710 24 ply Foam-Filled

### Accessories & Options

- Diesel Engine Deutz TCD 3.6 LRC
  - 36 x 72 in. (.91 x 1.83 m) Platform
  - Inward Self-Closing Swing Gate
  - Light Package<sup>3</sup>
  - Soft Touch System
  - Cold Weather Start Kit<sup>4</sup>
  - Hostile Environment Kit<sup>5</sup>
  - Flashing Amber Beacon
  - Cold Package Plus<sup>6</sup>
  - Special Hydraulic Oils
  - Skyguard beacon (ILOS)
  - Accessory Packages:
    - SkyAir®
    - SkyWelder®
    - SkyGlazier®
    - SkyPower® Package - 7500 Watt Generator Power Cable to Platform
3. Includes platform mounted worklights and drive/backup lights.  
4. Includes engine block heater, battery heater and oil tank heater.  
5. Includes console cover, boom wipers and cylinder bellows.  
6. Includes extreme cold engine oil, fuel conditioner, engine block heater, battery blanket, glow plugs, hydraulic tank heater, oversized footswitch and arctic hydraulic oil priced separately



0800 085 3709  
WWW.AERIALPLATFORMS.CO.UK

**HIRE NOW!**

Aerial Platforms Ltd, Denebrook Court, Greenfold Way, Leigh, WN7 3XJ

# Model 1500AJP

## ARTICULATING BOOM LIFTS

### Performance

• Working Height	48.15 m
• Working Outreach	23.55 m
• Up and Over Height	18.40 m
• Swing	360° Continuous
• Platform Capacity-Restricted	450 kg
• Platform Capacity-Unrestricted	270 kg
• Platform Rotator	180° Hydraulic
• Jib Length	2.44 m
• Jib Range of Articulation	130° (+75, -55)
• Jib Horizontal Rotation	125° (55 right, 70 left)
A. Platform Size	0.91 m x 2.44 m
B <sup>1</sup> . Overall Width (Axles Retracted)	2.50 m
B <sup>2</sup> . Overall Width (Axles Extended)	5.00 m
C. Tailswing (working condition)	0.70 m
D. Stowed Height	3.10 m
E <sup>1</sup> . Stowed Length	15.10 m
E <sup>2</sup> . Stowed Length (transport position)	12.10 m
F. Wheelbase (axles extended)	4.60 m
G. Ground Clearance	0.30 m
• Weight <sup>1</sup>	26,027 kg
• Max. Ground Bearing Pressure	8.6 kg/cm <sup>2</sup> TBD
• Drive Speed	4.5 km/h
• Gradeability	40%
• Turning Radius (Inside)	
• Axles Retracted	7.10 m
• Axles Extended	2.30 m
• Turning Radius (Outside)	
• Axles Retracted	9.50 m
• Axles Extended	6.60 m

<sup>1</sup> Certain options or country standards may increase weight and/or dimensions.



### Reach Diagram

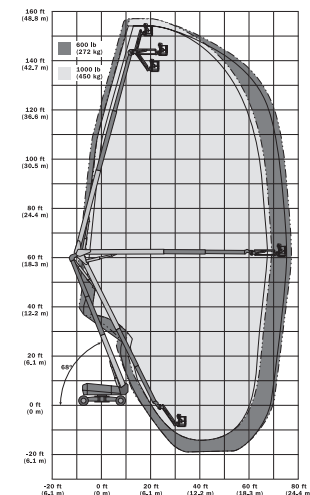

### Dimensions

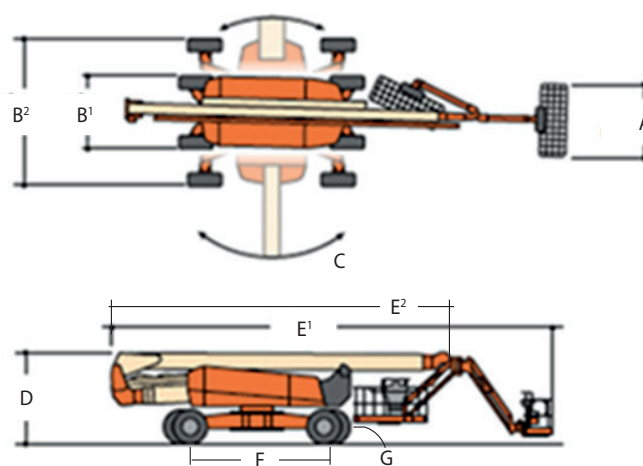

**0800 085 3709**  
[WWW.AERIALPLATFORMS.CO.UK](http://WWW.AERIALPLATFORMS.CO.UK)

**HIRE NOW!**

Aerial Platforms Ltd, Denebrook Court, Greenfold Way, Leigh, WN7 3XJ