

1250AJP

ARTICULATING BOOM LIFTS



MORE ECONOMIC

- Lower hydrocarbon, carbon monoxide, particulate and NOx emissions with Stage IIIB-compliant engine.

MORE PRODUCTIVE

- Equipped with hydrostatic drive for easy, precise, infinitely-variable-speed manoeuvrability. Go from ground to over 40m in under 115 seconds and enjoy industry best reach envelope with exclusive QuikStik® boom.

MORE ACCESS

- Conquer rough terrain with standard oscillating axle and four-wheel drive, delivering optimised grip and stability.

SMART DESIGN

- Customer-preferred controls mean fewer buttons and switches used to position the platform and less time spent learning to use the platform controls.

Standard Features

- 0.91 m x 2.44 m low mount platform
- Side entry with drop bar mid rail
- Multiple function operation
- Full proportional drive joystick control with integral thumb steer switch
- Full proportional main boom and swing joystick control
- Variable speed dial control for telescope, platform rotate and tower
- 2.44 m articulating jib
- JibPLUS® with 4 way axis jib including 125 degree horizontal motion
- Powered side stow on jib
- 180 degree powered platform rotator
- Platform console machine status light panel ¹
- Load sensing system
- AC power cable to platform
- Gull-wing turntable hoods
- Selectable dual platform capacity system (230kg/450kg)
- QuikStik® boom design feature
- Drive-out extending axles
- 5 degree tilt alarm and indicator light
- Oscillating front axle
- Lifting/tie down lugs
- Hour Meter
- Ground control selector switch with key lock
- Load Sensing Hydraulics
- Platform tool tray
- 12V-DC auxiliary power
- Engine distress warning/shut down system ²
- Multiple speed control for telescope, lower boom and platform rotate
- Low fuel engine cut-out
- Cast Aluminum Control Box
- Horn
- Hydrostatic drive transmission
- Swing-out engine tray
- Interactive Display at Ground Controls
- Control ADE® Advanced Design Electronics System
- JLG Skyguard active system

¹ Provides indicator lights at platform control console for system distress, low fuel, 5 degree tilt light, and foot switch status.

² Low oil pressure and high coolant temperature alarms with shut-down enabled/disabled by analyser.

Standard Specifications

Power Source

- Diesel Engine - Deutz TCD 2.9 L4 55.4 kW
- Fuel Tank Capacity 117 L

Hydraulic System

- Hydraulic System 390 L
- Auxiliary Power 12V DC

Tyres

- Tyres 445/50D710 Foam Filled

³ Available when integrated with the SkyPower® package.

⁵ Includes all-motion alarm and flashing amber beacon.

⁴ Consists of six 40-watt lights, four turntable mounted lights and two platform mounted lights.

⁶ Includes platform mounted work lights and head & tail lights.

⁷ Includes console cover, boom wipers and cylinder bellows.

Accessories & Options

- 0.91 m x 1.83 m slide bar side entry platform
- 0.91 m x 1.83 m Self closing inward swing gate
- 13 mm airline to platform
- On-board 4,000W generator
- SkyPower® package 7,500 watt on-board generator
- SkyWelder® package 250 amp welder in the platform ³
- SkyGlazier® package glass and panel tray
- Nite-Bright® package ⁴
- Alarm Package ⁵
- Light package ⁶
- Flashing amber beacon
- Euro Plug & Socket
- Hostile environment kit ⁷
- Hydraulic oil cooler
- Soft Touch 0.91 m x 1.83 m Platform Proximity System
- Soft Touch 0.91 m x 2.44 m Platform Proximity System
- Skyguard beacon (ILOS)
- Arctic package
- Generator hourmeter
- Synthetic Biodegradable Hydraulic Oil
- Platform worklights
- Head & Tail Lights
- Special paint colour



0800 085 3709
WWW.AERIALPLATFORMS.CO.UK

HIRE NOW!

Aerial Platforms Ltd, Denebrook Court, Greenfold Way, Leigh, WN7 3XJ

Model 1250AJP

ARTICULATING BOOM LIFTS

Performance

- Working Height 40.30 m
- Platform Height 38.30 m
- Working Outreach 19.90 m
- Horizontal Outreach 19.25 m
- Up and Over Height 18.44 m
- Swing (Continuous) 360°
- Platform Capacity – Restricted 450 kg
- Platform Capacity – Unrestricted 230 kg
- Platform Rotator (Hydraulic) 180°
- Jib – Overall Length 2.44 m
- Jib – Range of articulation 130° Vertical (+75°/-55°)
- JibPLUS[®] – Range of Articulation 125° Horizontal
 - A. Platform Size 0.91 m x 2.44 m
 - B. Overall Width (Axles Retracted) 2.49 m
 - Overall Width (Axles Extended) 3.81 m
 - C. Tailswing (working condition) 0.91 m
 - D. Stowed Height 3.05 m
 - E. Stowed Length (transport position) 11.46 m
 - F. Wheelbase 3.81 m
 - G. Ground Clearance 0.30 m
- Machine weight ^{1/2} 21,000 kg
- Maximum Ground Bearing Pressure 7.03 kg/cm²
- Drive Speed 5.2 km/h
- Gradeability 45%

¹ Certain options or country standards may increase weight and/or dimensions.

² With Standard tires



Reach Diagram

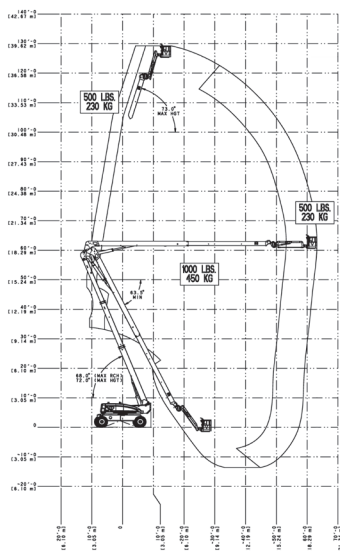

Dimensions

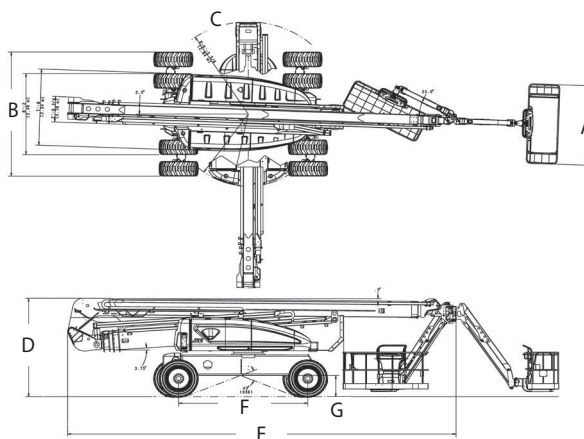

0800 085 3709
WWW.AERIALPLATFORMS.CO.UK

HIRE NOW!

Aerial Platforms Ltd, Denebrook Court, Greenfold Way, Leigh, WN7 3XJ