



ARTICULATING BOOM LIFT

AR14J / AR16J (AR45J / AR52J)



HIGHLIGHTS

LGMG AR Series articulating boom lifts are purpose built for outdoor construction and industrial applications. Simple and reliable design with industrial features make this machine easy to operate. A standard job offers the ability to reach even the most hard to reach places.

- Oscillating axels and four-wheel drive delivers better gradeability on rough terrain.
- Proportional smooth driving, precise positioning and comfortable operation.
- Self-leveling platform together with hydraulic platform rotation deliver exceptional productivity.
- Swing out engine tray for easy access and maintenance.
- Intelligent self diagnostic system for quick troubleshooting.



0800 085 3709

WWW.AERIALPLATFORMS.CO.UK

HIRE NOW!

Aerial Platforms Ltd, Denebrook Court, Greenfold Way, Leigh, WN7 3XJ

LGMG Diesel - Articulating Boom Lift

SPECIFICATIONS

MODELS	AR14J (AR45J)		AR16J (AR52J)	
Measurements	Metric	US	Metric	US
Working Height Max.	16.09m	52.79ft	17.70m	58.1ft
Platform Height	14.09m	46.23ft	15.7m	51.5ft
Horizontal Outreach	7.67m	25.16ft	9.39m	30.8ft
Up and Over Height	7.56m	24.8ft	7.56m	24.8ft
A Stowed Length	6.766m	22.2ft	7.56m	24.8ft
B Stowed Width	2.31m	7.58ft	2.31m	7.58ft
C Stowed Height	2.17m	7.1ft	2.17m	7.1ft
D Platform Length	1.83m	5.9ft	1.83m	5.9ft
E Platform Width	0.76m	2.6ft	0.76m	2.6ft
Platform Capacity	230kg	510lbs	230kg	510lbs
Wheelbase	2.059m	81in	2.059m	81in
Ground Clearance	0.36m	1.18ft	0.36m	1.18ft

PRODUCTIVITY				
Platform Occupants Max. (in/out)	2/2		2/2	
Drive Speed-Stowed	6.1km/h	3.8mph	6.1km/h	3.8mph
Drive Speed-Raised	0.8km/h	0.5mph	0.8km/h	0.5mph
Gradeability-Stowed	45%		45%	
Platform Rotator	160°		160°	
Turnable Rotation	355°		355°	
Turnable Tailswing	0		0	
Turning Radius-Inside	1.94m	6.36ft	1.94m	6.36ft
Turning Radius-Outside	4.41m	14.47ft	4.41m	14.47ft
Tires Type	RT Foam-filled		RT Foam-filled	
Tires Size	848×315mm	33.4×12.4in	848×315mm	33.4×12.4in

POWER				
Power Source	Deutz EU V Tier 4f 36.4kw/48.8hp			
Fuel Tank Capacity	65L	17.2gal	65L	17.2gal

HYDRAULIC SYSTEM				
Hydraulic Oil Capacity	130L	34.3gal	130L	34.3gal

WEIGHT				
Machine Weight(CE/ANSI)	7160kg	15785lbs	8180kg	18034lbs

Machines in compliant with EN280 / ANSI 92.20 Standard.

Specifications subject to change without notice. Photos and diagrams in the page are for promotional purposes only.

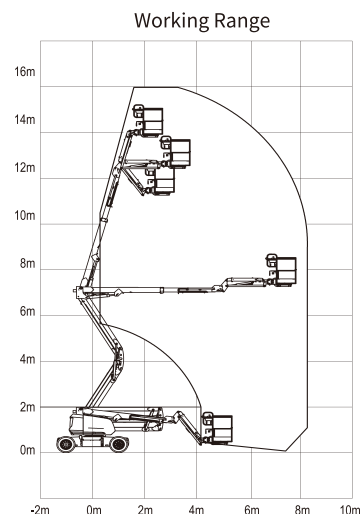
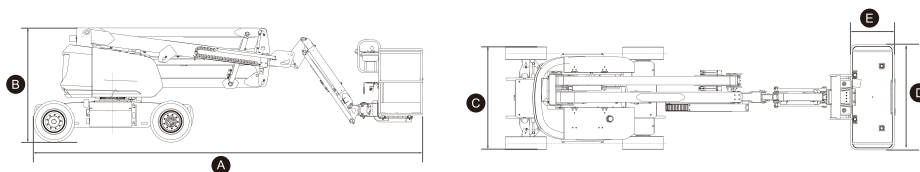

STANDARD FEATURES

- Proportional control
- Tilt alarm with lift cut-out
- Overload sensing system
- Descent alarm with flashing beacon
- Platform auto-leveling system
- Emergency stop button
- On-board diagnostic system
- Oscillating axle
- Four-wheel drive and break
- Over tilt protection system
- Anti-crush protection
- Horn/Hour meter
- Full-height drive

OPTIONAL

- AC power to platform
- Platform tool box
- Foam-filled non-marking tires
- Solid non-marking tires

2020 V1 Version



0800 085 3709

WWW.AERIALPLATFORMS.CO.UK

HIRE NOW!

Aerial Platforms Ltd, Denebrook Court, Greenfold Way, Leigh, WN7 3XJ