

# SELF-PROPELLED MINI SCISSOR LIFT

# S3010E

DIMENSIONS	S3010E
Max. working height	5.0m
Max. platform height ( A )	3.0m
Platform size	1.09m x 0.51m
Overall width ( B )	0.77m
Overall length ( C )	1.26m
Stowed height ( D )	1.8m
Ground clearance	58mm

PERFORMANCE	
Platform capacity (SWL)	227kg
Max. drive height	3.0m
Max. wind speed	0m/s
Max. drive speed (stowed)	3.5km/h
Max. drive speed (elevated)	0.64km/h
Raise/lower time	18/25 sec
Gradeability	25%
Max. operating slope	2°
Inside turning radius	0m
Outside turning radius	1.4m
Tyres	230mm dia. non-marking rubber
Parking brake	2-wheel automatic
Controls	2-axis proportional controls
Drive system	DC direct drive

POWER	
Power source	2 x 12V 105Ah
Battery charger	100-240V 50/60Hz Auto, 30 amp

WEIGHT	
Weight	495kg

## TURNING RADIUS

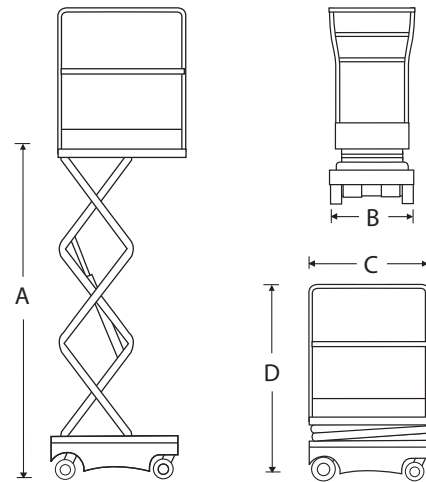
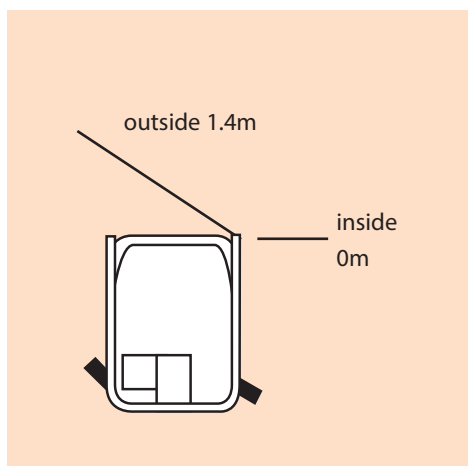

## STANDARD FEATURES

- Highly manoeuvrable skid steer
- Zero inside turning radius
- Saloon-door style entry gates
- 1 person + equipment capacity indoor
- Non-marking tyres
- Proportional point & go joystick controls
- Integrated battery charger
- Battery condition indicator
- Crane points & through-the-chassis fork pockets
- Selectable motion alarm
- Tilt & descent alarm
- Hour meter
- Horn
- 2 year parts & labour, 5 year structural warranty
- CE approved

## OPTIONS

- Special paint colours
- Environmental hydraulic oil
- Snorkel OnSite™ telematics

CE Specification  
© Snorkel 2021

Specifications subject to change without notice. Photos and diagrams in this brochure are for promotional purposes only. Refer to appropriate Snorkel operators manual for detailed instructions on the proper use and maintenance.



**0800 085 3709**  
**WWW.AERIALPLATFORMS.CO.UK**

**HIRE NOW!**

Aerial Platforms Ltd, Denebrook Court, Greenfold Way, Leigh, WN7 3XJ