

S2770BE/S3370BE/S3970BE

COMPACT BI-ENERGY ROUGH TERRAIN SCISSOR LIFTS



- Compact bi-energy scissor lifts
- Suitable for interior and exterior use
- Non-marking, high grip tyres
- Easy to operate
- Ideal for construction sites

 **snorkel**[™]
www.snorkellifts.com



0800 085 3709
WWW.AERIALPLATFORMS.CO.UK

Aerial Platforms Ltd, Denebrook Court, Greenfold Way, Leigh, WN7 3XJ

HIRE NOW!

COMPACT BI-ENERGY RT SCISSOR LIFTS

S2770BE/ S3370BE/S3970BE

DIMENSIONS	S2770BE	S3370BE	S3970BE
Max. working height	10.1m	12.0m	13.8m
Max. platform height (A)	8.1m	10.0m	11.8m
Platform size (stowed) (B)	1.6m x 2.8m	1.6m x 2.8m	1.6m x 2.8m
Platform size (extended) (C)	1.6m x 4.0m	1.6m x 4.0m	1.6m x 4.0m
Extension deck length	1.2m	1.2m	1.2m
Overall width (D)	1.8m	1.8m	1.8m
Stowed length (E)	3.4m	3.4m	3.4m
Stowed height (F)	2.61m	2.7m	2.95m
Min. height (guardrails folded)	1.83m	2.0m	2.13m
Ground clearance	330mm	330mm	330mm

PERFORMANCE			
Platform capacity (SWL)	580kg	454kg	350kg
Max. drive height	8.1m	10.0m	11.8m
Max. wind speed	12.5m/s	12.5m/s	12.5m/s
Max. drive speed (stowed)	4.5km/h (engine)		
Max. drive speed (elevated)	0.5km/h	0.3km/h	0.3km/h
Raise/lower time	26/30 sec	50/60 sec	50/60 sec
Gradeability	25%	25%	25%
Max. outrigger levelling, front to rear	6°	6°	6°
Max. outrigger levelling, side to side	10°	10°	10°
Inside turning radius	2.7m	2.7m	2.7m
Outside turning radius	5.0m	5.0m	5.0m
Tyres	27 x 10.5 foam filled, non-marking		
Controls	proportional joystick		
Drive system	4-wheel drive		

POWER	
Power source	Kubota D-902 water-cooled diesel 22.5hp - Tier 4 Final and 4 x 6v 305Ah batteries

WEIGHT			
Weight	3,186kg	3,919kg	4,090kg

TURNING RADIUS

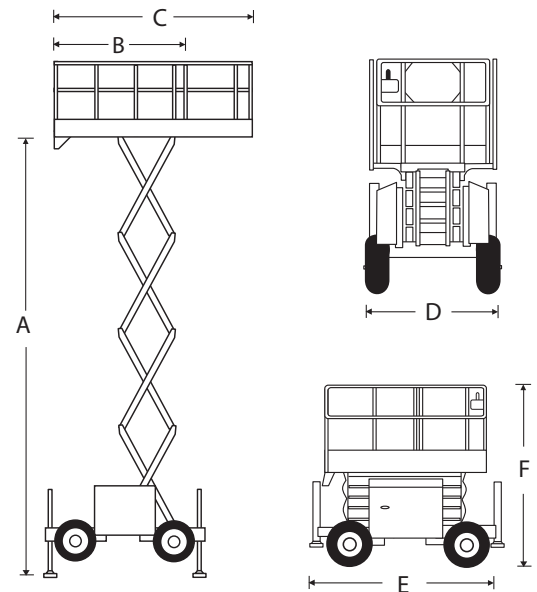
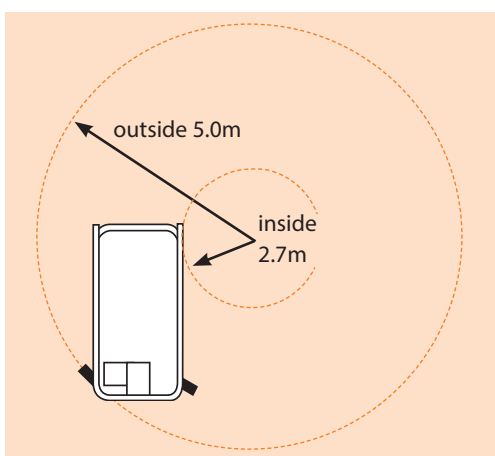

STANDARD FEATURES

- DC and diesel power - for indoor & outdoor work
- 4-wheel drive
- 4 hydraulic outriggers with automatic levelling
- Roll-out deck extension
- Non-marking tyres
- Proportional controls
- Flashing amber light
- Oscillating axle
- Power line to platform
- Drive motion alarm
- Descent alarm
- Fold-down guardrails
- Hour meter & on-board diagnostics display
- Dual lanyard attachment points
- Manual lowering valve
- 2 year parts & labour, 5 year structural warranty
- CE approved

OPTIONS

- Special paint colours
- Hydraulic generator 110V/240V
- Nylon spreader pads (set of 4)
- Environmental hydraulic oil
- Cold weather package
- Snorkel OnSite™ telematics

CE Specification
© Snorkel 2021

Specifications subject to change without notice. Photos and diagrams in this brochure are for promotional purposes only. Refer to appropriate Snorkel operators manual for detailed instructions on the proper use and maintenance.



0800 085 3709
WWW.AERIALPLATFORMS.CO.UK

HIRE NOW!

Aerial Platforms Ltd, Denebrook Court, Greenfold Way, Leigh, WN7 3XJ