



TELESCOPIC BOOM LIFT

T20J / T26J (T65J / T85J)

HIGHLIGHTS

LGMG T Series telescopic boom lifts offer great outreach with high working efficiency. Its exceptional all terrain capacities allow the machine to operate on the roughest ground and complete the tasks on time.

- Oscillating axels and four-wheel drive delivers better gradeability on rough terrain.
- Proportional control ensures smooth driving, precise positioning and comfortable operation.
- Continuous 360° turntable rotation expands the operational area and makes operations more convenient.
- Swing out engine tray for easy access and maintenance.
- Intelligent self-diagnostic system for quick troubleshooting.



0800 085 3709

WWW.AERIALPLATFORMS.CO.UK

HIRE NOW!

Aerial Platforms Ltd, Denebrook Court, Greenfold Way, Leigh, WN7 3FZ

 PART OF THE CENTURION GROUP

LGMG Diesel - Telescopic Boom Lift

SPECIFICATIONS

MODELS	T20J (T65J)		T26J (T85J)	
Measurements	Metric	US	Metric	US
Working Height Max.	21.7m	71.2ft	27.9m	91.5ft
Platform Height	19.7m	64.6ft	25.9m	84.9ft
Horizontal Outreach	17.2m	56.4ft	23.32m	76.5ft
Below Ground Reach	2.72m	8.92ft	2.89m	9.48ft
Platform Length	1.83m	72in	2.44m	96in
Platform Width	0.76m	30in	0.91m	36in
Platform Capacity	250kg	551lbs	250/340kg	551/750lbs
A Stowed Length	9.47m	31.07ft	12.6m	41.3ft
B Overall Width	2.495m	8.186ft	2.5m	8.2ft
C Stowed Height	2.77m	9.09ft	2.86m	9.38ft
D Wheelbase	2.51m	8.24ft	2.85m	9.35ft
Ground Clearance	0.395m	1.296ft	0.44m	1.44ft

PRODUCTIVITY				
Platform Occupants Max. (in/out)	2/2	2/2	2/2	2/2
Turntable Rotation	360°Continuous		360°Continuous	
Turntable Tailswing	1.22m	4ft	1.42m	4.66ft
Drive Speed-Stowed	4.8km/h	3mph	4.8km/h	3mph
Drive Speed-Raised	0.8km/h	0.5mph	0.8km/h	0.5mph
Gradeability-Stowed	45%		45%	
Max. Wind Speed	12.5m/s	28mph	12.5m/s	28mph
Turning Radius-Inside	2.5m	8.2ft	3.66m	12ft
Turning Radius-Outside	5.5m	18ft	6.55m	21.5ft
Max.Slope	2.5/4.5°		2.5/4.5°	
Tires Type	RT Foam-filled		RT Foam-filled	
Tires Size	355/55D 625		18-625	

POWER				
power source	Deutz D 2.9L4 36.4kw/48.8hp		Deutz TD 2.9L4 55.4kw/74.3hp	
Fuel Tank Capacity	100L	26.4gal	100L	26.4gal

HYDRAULIC SYSTEM				
Hydraulic Oil Capacity	180L	47.5gal	180L	47.5gal

WEIGHT				
Machine Weight(CE/ANSI)	11400kg	25132lbs	18000kg	39683lbs

Machines in compliant with EN280 / ANSI 92.20 Standard.

Specifications subject to change without notice. Photos and diagrams in the page are for promotional purposes only.

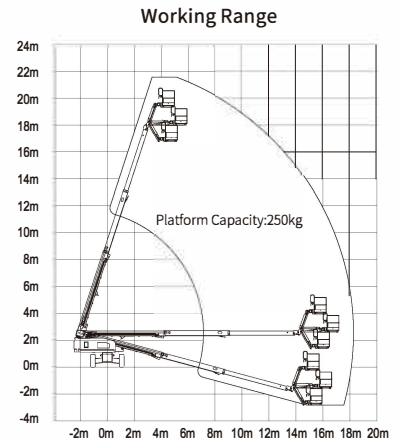
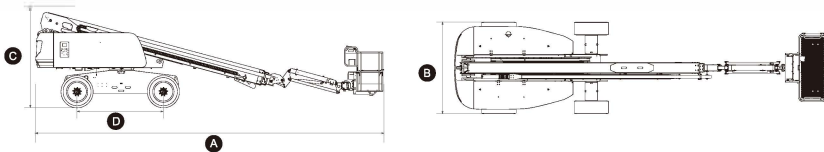

STANDARD FEATURES

- Proportional control
- Tilt alarm with lift cut-out
- Overload sensing system
- Descent alarm with flashing beacon
- Platform auto-leveling system
- Emergency stop button
- On-board diagnostic system
- Oscillating axle
- Four-wheel drive and break
- Overtilt protection system
- Anti-crush protection
- Horn/Hour meter

OPTIONAL

- AC power to platform
- Platform tool box
- Euro V engine
- T4F engine

2020 V1 Version

LINGONG GROUP JINAN HEAVY MACHINERY CO., LTD.

Address: No. 2676, Kejia Road, Jinan, Shandong, China

Email: sales@lmg.com.cn



0800 085 3709

WWW.AERIALPLATFORMS.CO.UK

HIRE NOW!

Aerial Platforms Ltd, Denebrook Court, Greenfold Way, Leigh, WN7 3FZ

PART OF THE CENTURION GROUP